

2		Pressfixtur "slimmad"	2022-10-19	MK
1		Tillkom	2021-03-23	MK
Rev	Dcn number	Change description	Date	Sign

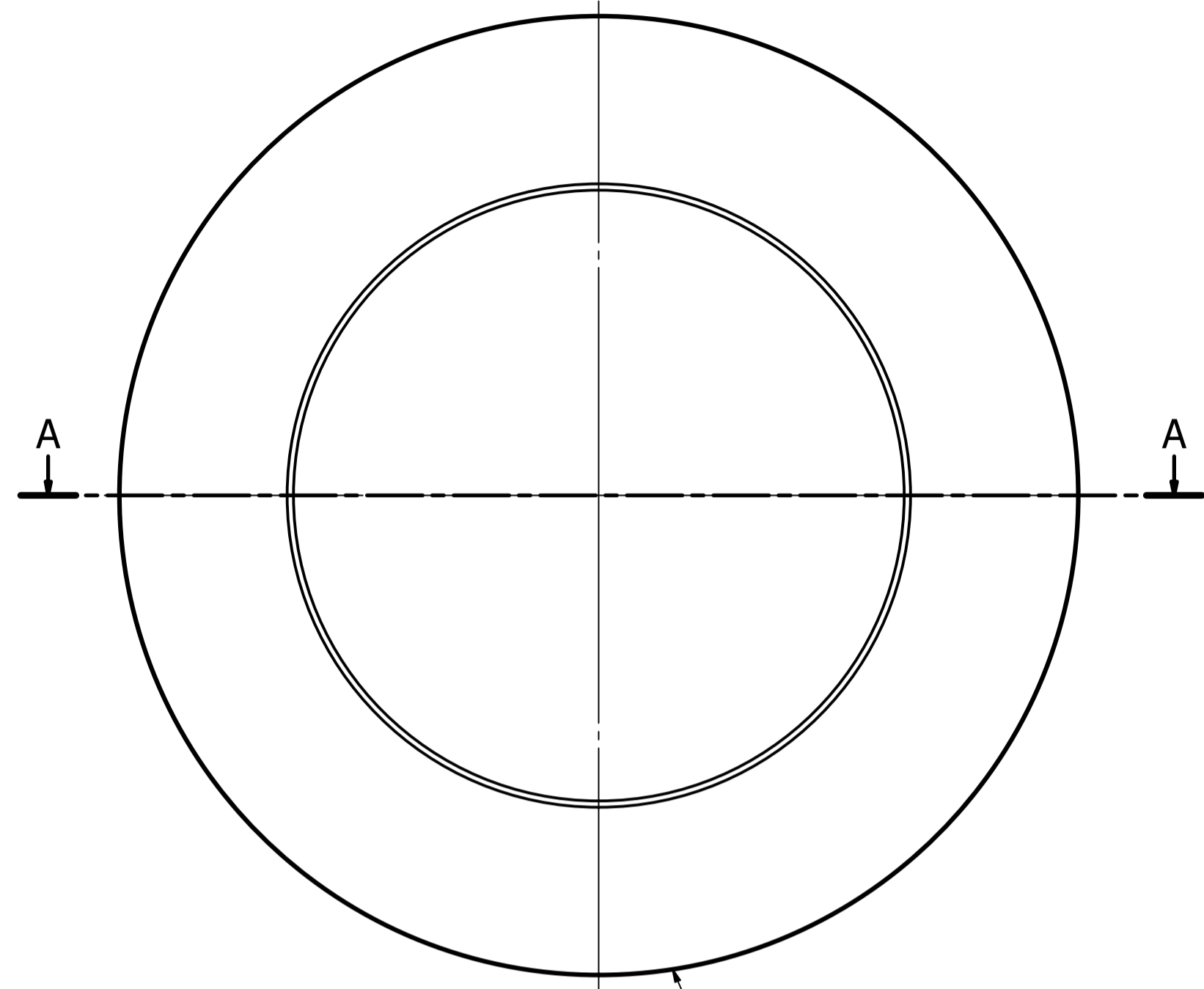

Item 1: Steel SS 2172 alt. similar  
▽ (▽▽)

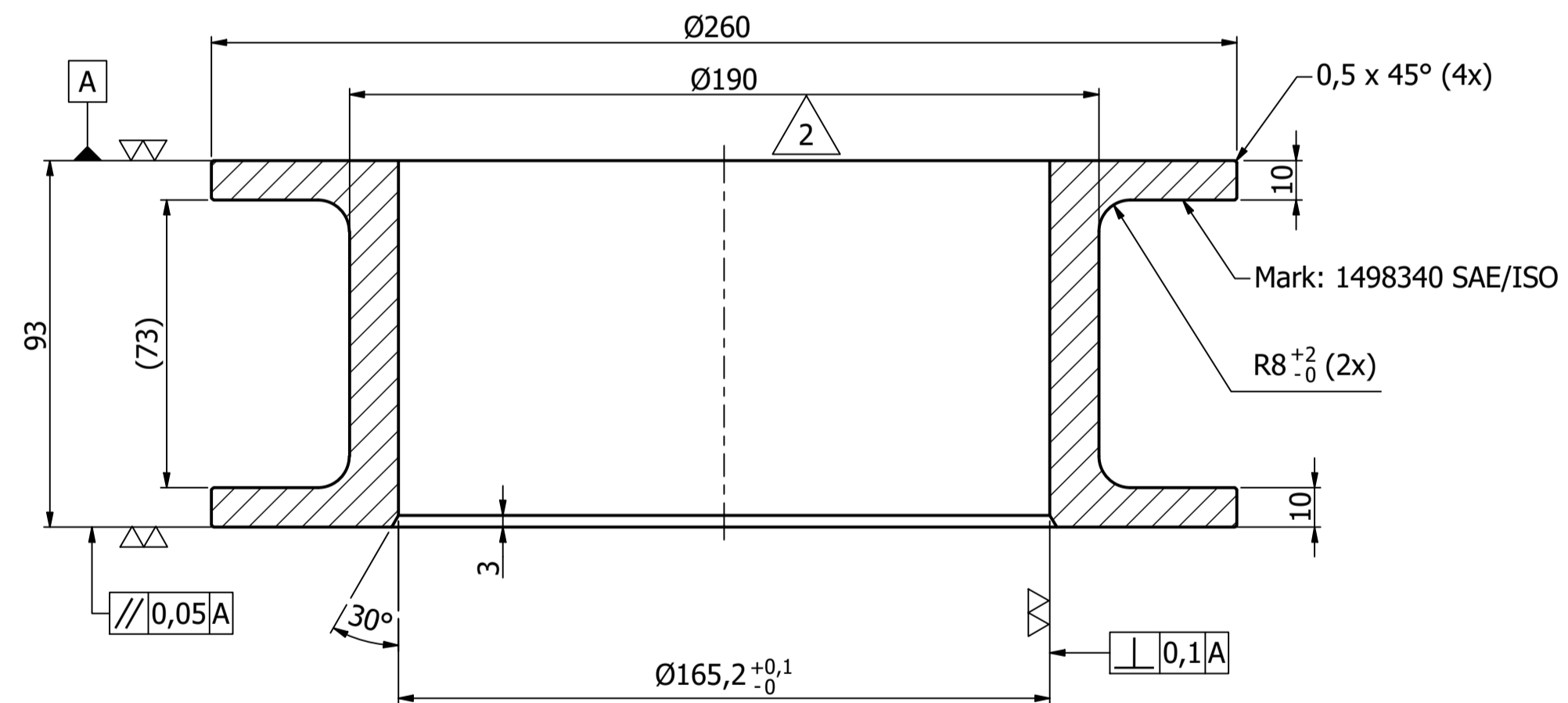
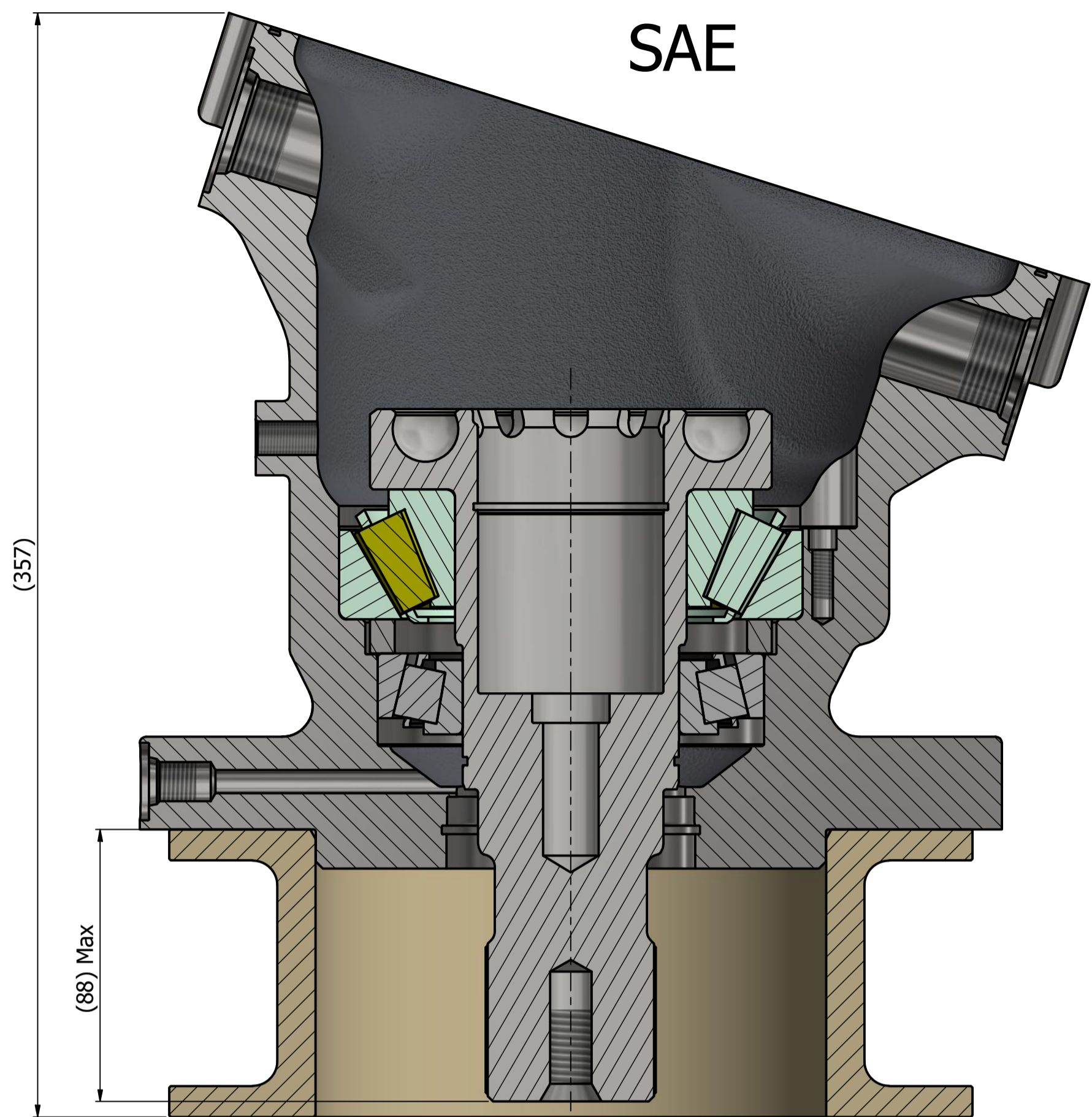
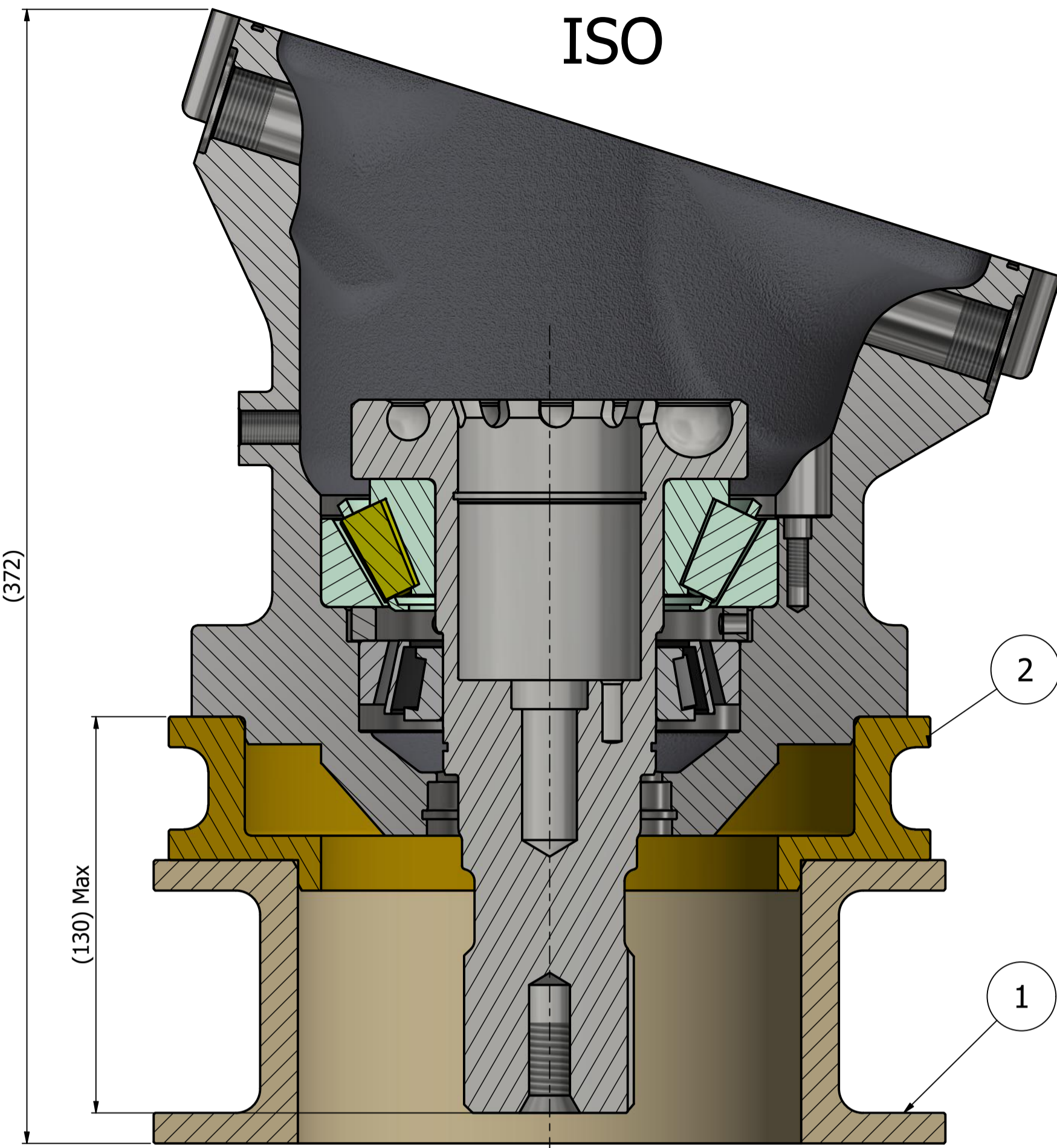

A-A ( 1 : 1,5 )

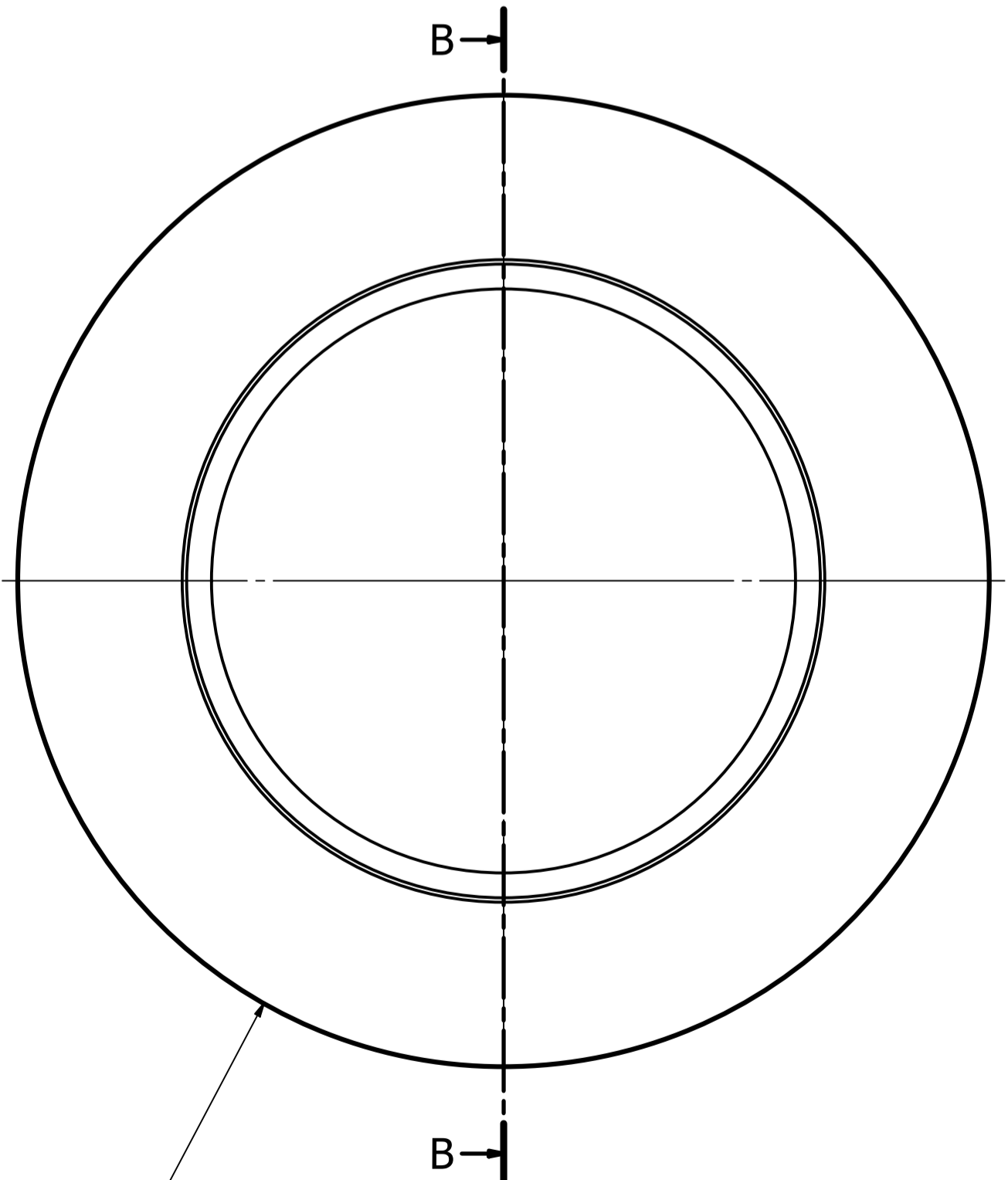

Item 2: Steel SS 2172 alt. similar  
▽ (▽▽)

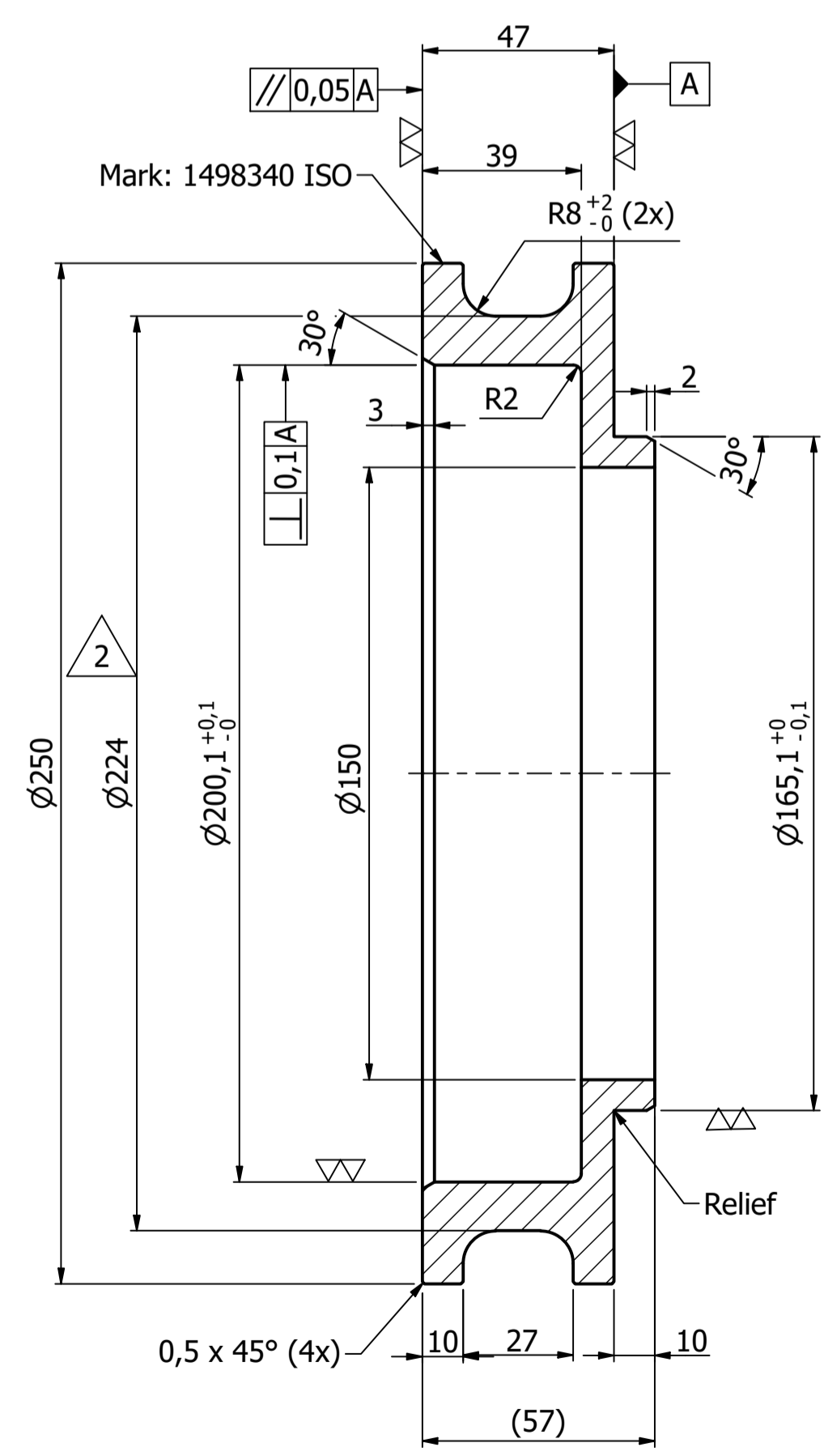

B-B ( 1 : 1,5 )

Parts list			
Item	Qty	Part number	Description
1	1	1498340_1	
2	1	1498340_2	

±0,25	±0,5°	▽	0,1-0,4
-------	-------	---	---------

Skala/Scale: 1 : 1,5

Projection: 1st Angle

Arbetsnamn: Tool for insertion of shaft assy into housing

Part Title: V16

Utförd av/Issued by: mk69874

Godkänd av ML

Utgåva: 2

Blad/Sit: 1 (1)

Datum/Date: 2021-03-23

1498340\_english version

Utskrift är registrerad kopia./Printed copies are uncontrolled.

Notice: This document contains proprietary information and shall not be used or its contents disclosed, in whole or in part, without the prior written consent of Parker Hannifin Manufacturing Sweden AB.